

Inc. Village of Hewlett Bay Park

30 Piermont Ave · Hewlett · New York · 11557
T: (516) 295-1400 F: (516) 295-1406



Building Department

BuildingInspector@hewlettbayparkny.gov
Buildingdepartment@hewlettbayparkny.gov

Driveway/Pavement Permit Application Requirements

- ❖ Completed permit application form
- ❖ Application Fee: \$200.00 (non-refundable)
- ❖ Two (2) Up-to-date surveys and plot plan must include:
 - Plot plan indicating all dimensions and square footage of proposed work.
 - Zoning chart to include impervious surface coverage calculations as per code.
 - Drainage calculations (5-inch rainfall), with location of drainage structure(s) and piping.

Additional Information

- ❖ All Contractors must submit
Nassau County Consumer Affairs License (Copy of the original license).
Liability Insurance with the Village of Hewlett Bay Park as the certificate holder and additionally insured. Accord form Only. (Insurance must list everything the contractor is insured to do).
Workers Compensation Insurance with the Village of Hewlett Bay Park as the certificate holder. Forms must be C 105.2, or U-26.3, or CE 200 for waiver.
- ❖ Applications will be reviewed upon the submission of all required items.

Incomplete applications will not be accepted!

NO WORK SHALL BEGIN UNTIL A PERMIT HAS BEEN ISSUED



Date: _____

Village of Hewlett Bay Park

PERMEABLE PAVER OWNER & CONTRACTOR CONSENT

Property: _____

Section: _____ Block: _____ Lot(s): _____

- Gap/Openings must be a minimum of 3/8 inch
- 13% of Surface shall be pervious
- Pavers must be **Interlocking** & approved by the Village

***NOTE: STEPPINGSTONES AND SLABS WILL NOT BE CONSIDERED AS PERMEABLE.**

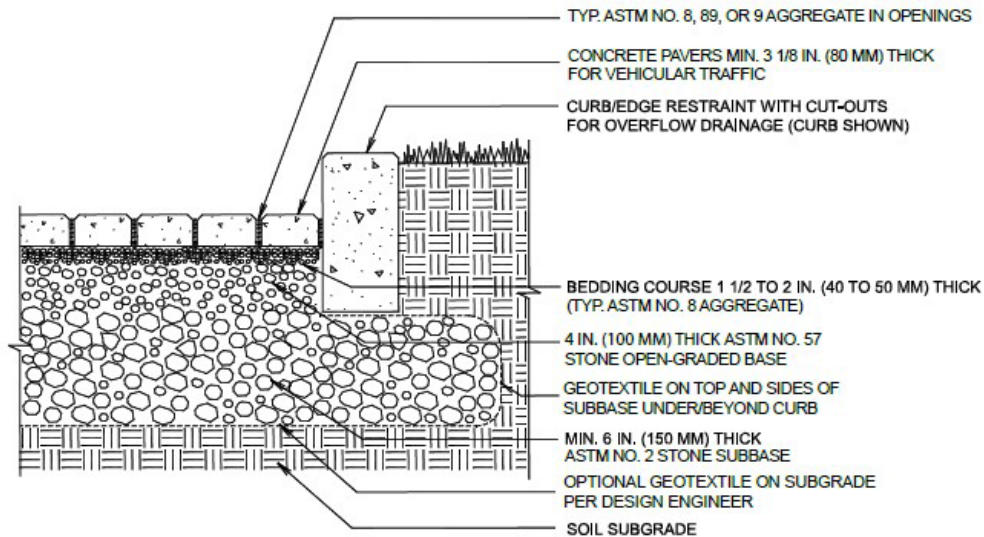

Figure 4. Full exfiltration cross section allows storage and infiltration. Overflows are to swales, bioretention areas or storm sewer inlets.

Required Inspections by the Building Department:

1. Excavation and permeability substrate soil condition.
2. Installation of gravel base to required depth & size.
3. Final installation of pavers.

We, the undersigned understand and agree to the requirements of the installation of permeable interlocking paver system and will contact the Building Department for the required inspections. We understand that if the pavers are not the approved type and/or are not installed properly, both paver and substrate will have to be removed and the correct paver and installation will be required.

Owner: _____
(PRINT NAME)

Contractor: _____
(PRINT NAME)

Signature: _____

Signature: _____



Village of Hewlett Bay Park
OWNERS ACKNOWLEDGEMENT AFFIDAVIT

I, _____ being duly sworn, depose and say that I am the owner of _____, and that I have authorized the work to be performed at my property by _____ (Contractor).

I have read and understand the responsibilities stated below as the homeowner and person responsible while work is being performed on my property. I have familiarized myself with the conditions set forth for the issuance of the building permit as well as the Code of the Village of Hewlett Bay Park including but not limited to:

1. The Building Permit is valid for one (1) year from the date of issuance stated on the permit. If for any reason the work is not completed before the expiration date, you must obtain a six (6) month extension by submitting a request along with the fee that is due prior to the expiration date to be heard before the Board of Trustees for approval.
2. In order to obtain a Certificate of Occupancy or Completion the required documents must be submitted. (Electrical Certificate, Final Survey, any related documents required by the Building Inspector) and ALL inspections must be completed. The **homeowner** is responsible for all open permits.
3. Hours work can be done:
 - a. Monday through Friday - 8:00am to 6:00pm
 - b. **Saturdays, Sundays and Legal holidays - NO WORK**
4. The property must be kept clean and in safe condition at all times during construction.
5. Any and all changes to the approved plans must be submitted to the Building Department and approved by the Inspector.
6. Make sure your contractor has their vehicles parked legally along the street if they cannot park in your driveway.

I make this affidavit with the full knowledge that the Building Department relies upon the truth of the statements herein contained and in relying thereon will issue a permit called for in the application.

(Property Owner's Signature)

Sworn to before me this

_____ day of _____, 20__

(Notary's Signature)

Notary Stamp:

VILLAGE CURBING DETAIL

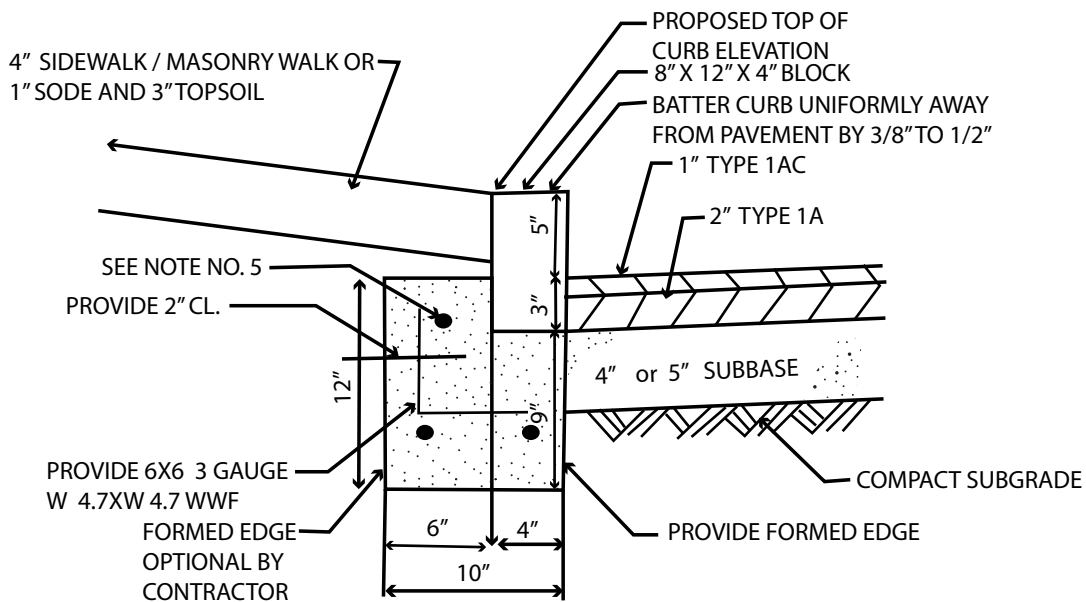
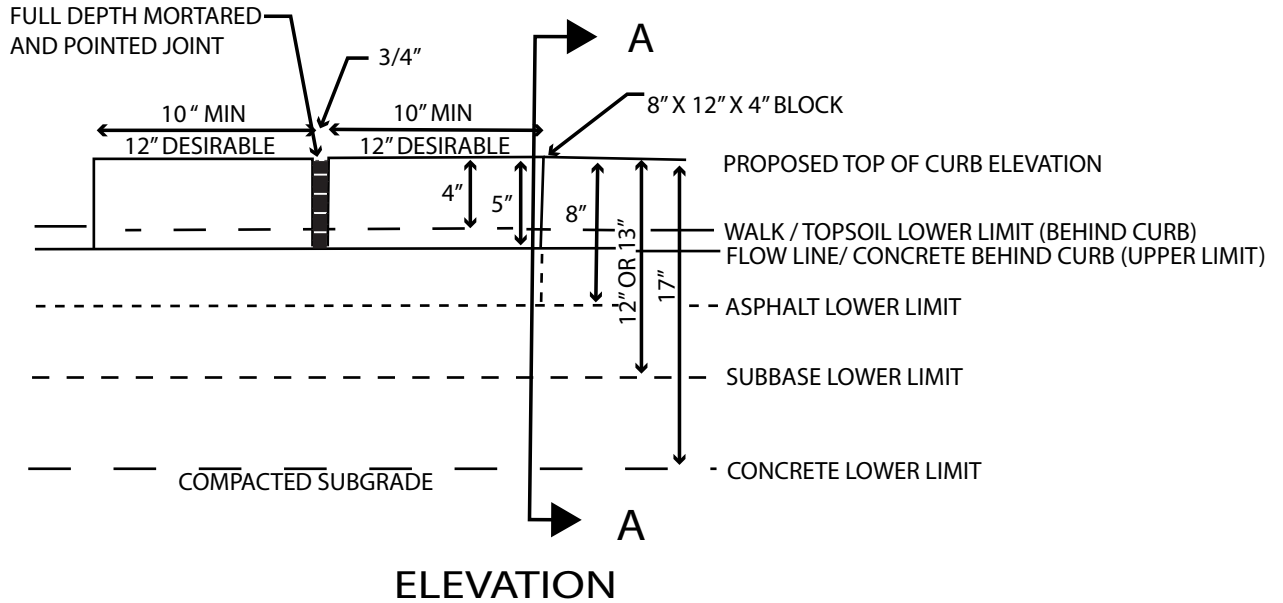

SECTION A - A
AT DRIVEWAYS AND SIDEWALK CURB RAMPS

STONE BLOCK CURB

ITEM 26 BG
NOT TO SCALE

NOTES:

1. PROVIDE 4000 PSI CLASS "A" CONCRETE
2. ALL DROP CURBS SHALL BE ITEM 26.
3. JOINTS SHALL BE 1:2 MORTAR MIX
4. JOINTS SHALL BE FULL DEPTH MORTARED AND POINTED.
5. OPTIONAL REINFORCEMENT (3) #3 O 6" O.C
6. BLOCK SIZE INDICATED IS MINIMUM DIMENSION REQUIRED UNLESS INDICATED OTHERWISE.
7. PROVIDE EXPANSION JOINTS AT LOCATIONS REQUIRED BY ITEM 2.
8. ROADSIDE VERTICAL EDGE OF CURB SHALL BE FORMED.